

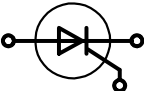

Type	Ag* Al*	V _{DRM} / V _{RRM}	V _{DSM} / V _{RSM} [V]	I _{T(AV)} [A]	Chip Size [mm] x [mm]	Package Options	
CWP 16-16	<input checked="" type="checkbox"/> <input checked="" type="checkbox"/>	1600	1700	27	6.50 6.50	sawn on foil <input checked="" type="checkbox"/> unsawn wafer <input checked="" type="checkbox"/> * in waffle pack <input checked="" type="checkbox"/>	
*Frontside options						*Please contact IXYS chip sales	

Mechanical Parameters

Area active	0.15	cm ²
Area total	0.42	cm ²
Wafer size Ø	150	mm
Thickness	380	µm
Material	Si	
Max. possible chips per wafer	342	
Passivation front side	Glassivation	
Metallization top side	solderable: Ti / Ni / Ag *	
top side	bondable: Al	
Recom. wire bonds (Al)	Cathode	Gate
Number / Ø [µm]	5 / 380	1 / 380
Metallization backside	solderable (only): Ti / Ni / Ag *	
Reject Ink Dot Size	Ø 0.4-1.0 mm	
Recom. Storage Environment		
sawn on foil	in org. container, in dry nitrogen	< 6 month
unsawn wafer	in org. container, in dry nitrogen	< 2 year
in waffle pack	in org. container, in dry nitrogen	< 2 year
T _{stg}	-40 ...	40 °C

Features

- planar passivated with guardring and channelstopper
- Planar front and back surface
- Non-structured anode contact on full area bottom side

Applications

- DC motor control
- AC power control
- Softstart AC motor controller
- Light, heat and temperature control

*Sinterable top/bottom side on request

Dimensions

A	B	C	D	E	H	J	K	L
[mm]	[mm]	[mm]	[mm]	[mm]	[mm]	[mm]	[mm]	[mm]
6.50	6.50	4.32	4.32	0.34	1.50	0.40	0.40	1.50

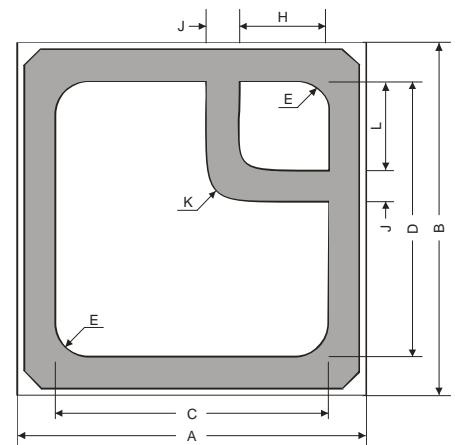
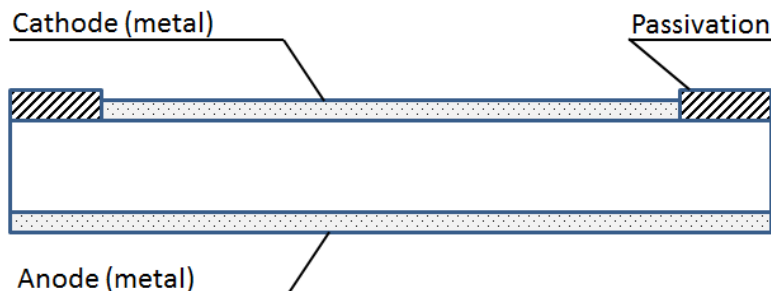

Electrical parameters

Symbol	Conditions	Ratings		
		min.	typ.	max.
I_R	$V_D = V_r = V_{rr}$ $T_{VJ} = 25^\circ\text{C}$ $T_{VJ} = 150^\circ\text{C}$			0.05 mA 8 mA
V_T	$I_T = 45\text{ A}$ $T_{VJ} = 25^\circ\text{C}$ $T_{VJ} = 150^\circ\text{C}$			1.40 V 1.45 V
V_{T0}	For power-loss calculations only			0.9 V
r_T	$T_{VJ} = 150^\circ\text{C}$			12.00 mΩ
V_{GT}	$V_D = 6\text{ V}$ $T_{VJ} = 25^\circ\text{C}$ $T_{VJ} = -40^\circ\text{C}$			1.5 V 1.6 V
I_{GT}	$V_D = 6\text{ V}$ $T_{VJ} = 25^\circ\text{C}$ $T_{VJ} = -40^\circ\text{C}$			42 mA 80 mA
V_{GD}	$T_{VJ} = 150^\circ\text{C}$ $V = \frac{2}{3} V_{DRM}$			0.2 V
I_{GD}				3 mA
I_L	$t_p = 10\ \mu\text{s}$ $T_{VJ} = 25^\circ\text{C}$ $I_G = 0.3\text{ A}$ $di_G/dt = 0.3\text{ A}/\mu\text{s}$			150 mA
I_H	$R_{GK} = \infty$ $T_{VJ} = 25^\circ\text{C}$ $V_D = 6\text{ V}$			100 mA
t_{gd}	$V_D = \frac{1}{2} V_{DRM}$ $T_{VJ} = 25^\circ\text{C}$ $I_G = 0.5\text{ A}$ $di_G/dt = 0.5\text{ A}/\mu$			2 μs
t_q	$V_R = 100\text{ V}$ $I_T = 27\text{ A}$ $-di/dt = 10\text{ A}/\mu\text{s}$ $t_p = 200\ \mu\text{s}$ $dv/dt = 20\text{ V}/\mu\text{s}$ $V_D = \frac{2}{3} V_{DRM}$ $T_{VJ} = 125^\circ\text{C}$			200 μs
$(di/dt)_{cr}$	repetitive $I_T = 40\text{ A}$ non repetitive $I_T = 27\text{ A}$ $V = \frac{2}{3} V_{DRM}$ $T_{VJ} = 150^\circ\text{C}$ $di_G/dt = 0.3\text{ A}/\mu\text{s}$ $I_G = 0.3\text{ A}$ $t_p = 200\ \mu\text{s}$ $f = 50\text{ Hz}$			100 A/ μs 500 A/ μs
$(dv/dt)_{cr}$	$T_{VJ} = 150^\circ\text{C}$ $V_{DR} = \frac{2}{3} V_{DRM}$ $R_{GK} = \infty$ method 1 (linear voltage rise)			1000 V/ μs
P_{GM}	$T_{VJ} = 150^\circ\text{C}$ $t_p = 30\ \mu\text{s}$ $t_p = 3E\ \mu\text{s}$			10 W 5 W
P_{GAV}				0.5 W
V_{RGM}				10 V
T_{VJ}		-40		150 $^\circ\text{C}$
$I_{T(AV)}$	$T_C = 100^\circ\text{C}$ 180° rect. $T_{VJ} = 150^\circ\text{C}$ 180° sine			27 A 25 A
I_{TSM}^*	$T_{VJ} = 45^\circ\text{C}$ $t = 10\text{ ms}$ (50) Hz, sine $V_R = 0\text{ V}$ $t = 8.3\text{ ms}$ (60) Hz, sine $T_{VJ} = 150^\circ\text{C}$ $t = 10\text{ ms}$ (50) Hz, sine $V_R = 0\text{ V}$ $t = 8.3\text{ ms}$ (60) Hz, sine			400 A 430 A 360 A 380 A
I^2t^*	$T_{VJ} = 45^\circ\text{C}$ $t = 10\text{ ms}$ (50) Hz, sine $V_R = 0\text{ V}$ $t = 8.3\text{ ms}$ (60) Hz, sine $T_{VJ} = 150^\circ\text{C}$ $t = 10\text{ ms}$ (50) Hz, sine $V_R = 0\text{ V}$ $t = 8.3\text{ ms}$ (60) Hz, sine			800 A s ² 767 A s ² 648 A s ² 599 A s ²
R_{thJC}^*	DC current		1.2	K/W

* Data according to assembled product MMO 36

Data according to IEC 60747

Terms of Conditions and Usage

The data contained in this product data sheet is exclusively intended for technically trained staff. The user will have to evaluate the suitability of the product for the intended application and the completeness of the product data with respect to his application. The specifications of our components may not be considered as an assurance of component characteristics. Should you require product information in excess of the data given in this product data sheet or which concerns the specific application of our product, please contact the sales office, which is responsible for you. Due to technical requirements our product may contain dangerous substances. For any information on the types in question please contact the sales office/partner, which is responsible for you.

Should you intend to use the product in aviation applications, in health or life endangering or life support applications, please notify. For any such applications we urgently recommend

- to perform joint risk and quality assessments;
- the conclusion of quality agreements;
- to establish joint measures to ensure application specific product capabilities and notify that IXYS may delivery dependent on the realization of any such measures.